

# QT020

## Liquid Cooled Gas Engine Generator Sets

Standby Power Rating  
20 kW 60 Hz



### **GENERAC 1.6L ENGINE**

Naturally Aspirated  
Gaseous Fueled

## STANDARD EQUIPMENT

- All input connections in one single area
- High coolant temperature shutdown
- Low oil pressure shutdown
- Low coolant level automatic shutdown
- Overspeed automatic shutdown
- Crank timer
- Exercise timer
- Oil drain extension
- Cool flow radiator
- Closed coolant recovery system
- UV/Ozone resistant hoses
- Watertight state of the art electrical connectors
- Mainline circuit breaker
- Radiator drain extension
- Battery charge alternator
- 2 Amp static battery charger
- Battery and battery cables
- Battery rack
- Fan and belt guards
- Isochronous governor

## FEATURES

- Innovative design and fully prototype tested
- UL2200 Listed
- Solid state frequency compensated voltage regulator
- Dynamic and static battery charger
- Sound attenuated acoustically designed enclosure
- Quiet test for low noise level exercise
- Acoustically designed engine cooling system
- High flow low noise factory engineered exhaust system
- State of the art digital control system with R100 digital control panel
- Watertight electrical connectors
- Rodent proof construction
- High efficiency, low distortion Generac designed alternator
- Vibration isolated from mounting base
- Matching Generac transfer switches engineered and tested to work as a system
- All components easily accessible for maintenance
- Electrostatically applied powder paint

**GENERAC**<sup>®</sup>  
POWER SYSTEMS, INC.

## GENERATOR SPECIFICATIONS

TYPE .....	Synchronous
ROTOR INSULATION.....	Class F
STATOR INSULATION.....	Class F
TOTAL HARMONIC DISTORTION.....	<5%
TELEPHONE INTERFERENCE FACTOR (TIF) .....	<50
ALTERNATOR OUTPUT LEADS 3 PHASE .....	4 wire
BEARINGS.....	Sealed Ball
COUPLING.....	Flexible Disc
LOAD CAPACITY (STANDBY RATING).....	20 kW
EXCITATION SYSTEM.....	Direct

**NOTE:** Generator rating and performance in accordance with ISO8528-5, BS5514, SAE J1349, ISO3046, and DIN6271 standards.

## VOLTAGE REGULATOR

TYPE .....	Electronic
SENSING .....	Single Phase
REGULATION.....	± 1%
FEATURES.....	V/F Adjustable Adjustable Voltage and Gain LED Indicators

## GENERATOR FEATURES

- Revolving field heavy duty generator
- Directly connected to the engine
- Operating temperature rise 120 °C above a 40 °C ambient
- Insulation is Class F rated at 130 °C rise
- All models are fully prototyped tested

## CONTROL PANEL FEATURES

- |  |   |
|--|---|
| <input type="checkbox"/> SEVEN LED INDICATOR LIGHTS  | <input type="checkbox"/> ADDITIONAL FUNCTIONS   |
| <ul style="list-style-type: none"><li>• System ready</li><li>• Low fuel pressure</li><li>• Low battery</li><li>• Low oil pressure</li><li>• High coolant temp/low coolant temp</li><li>• Overspeed</li><li>• Overcrank</li></ul> | <ul style="list-style-type: none"><li>• Utility sensing</li><li>• Delay on utility failure for engine start</li><li>• Engine warm-up before transfer</li><li>• Delay to retransfer to utility</li><li>• Engine cooldown timer</li><li>• Exerciser not set</li></ul> |
- 
- INTERNAL FUNCTIONS:
    - 3 position switch (auto, off and manual)
    - 2 wire start for any transfer switch
    - Communicates with the Generac RTS transfer switch
    - Built-in 7 day exerciser
    - Selectable engine speed at exercise
    - Governor controller is built into the master control board
    - Temperature range -40 °C to 70 °C

## ENGINE SPECIFICATIONS

MAKE .....	Generac
MODEL.....	In line
CYLINDERS.....	4
DISPLACEMENT.....	1.6 Liter
BORE.....	3.15
STROKE.....	3.13
COMPRESSION RATIO.....	9.75:1
INTAKE AIR SYSTEM.....	Naturally Aspirated
VALVE SEATS.....	Replaceable
LIFTER TYPE.....	Hydraulic

## GOVERNOR SPECIFICATIONS

TYPE .....	Electronic
FREQUENCY REGULATION.....	Isochronous
STEADY STATE REGULATION.....	± 0.25

## ENGINE LUBRICATION SYSTEM

OIL PUMP.....	Gear
OIL FILTER.....	Full flow spin-on cartridge
CRANKCASE CAPACITY.....	4 Quarts

## ENGINE COOLING SYSTEM

TYPE .....	Closed
WATER PUMP.....	Belt driven
FAN SPEED.....	2550
FAN DIAMETER.....	15 inches
FAN MODE.....	Pusher

## FUEL SYSTEM

FUEL TYPE.....	Natural gas, propane vapor
CARBURETOR.....	Down Draft
SECONDARY FUEL REGULATOR.....	Standard
FUEL SHUT OFF SOLENOID .....	Standard
OPERATING FUEL PRESSURE.....	.5" - 14" H <sub>2</sub> O

## ELECTRICAL SYSTEM

BATTERY CHARGE ALTERNATOR.....	12V 30 Amp
STATIC BATTERY CHARGER .....	2 Amp
RECOMMENDED BATTERY .....	Group 26, 525CCA
SYSTEM VOLTAGE.....	12 Volts

QT020

**OPERATING DATA**

		QT020		
<b>KW RATING</b>		20		
<b>ENGINE SIZE</b>		1.6 Liter 4 cyl. inline		
<b>GENERATOR OUTPUT VOLTAGE/KW - 60Hz</b>		<b>KW</b>	<b>AMP</b>	<b>CB Size</b>
120/240V, 1-phase, 1.0 pf		20	83	100
120/208V, 3-phase, 0.8 pf		20	69	80
<b>GENERATOR LOCKED ROTOR KVA AVAILABLE @ VOLTAGE DIP OF 35%</b>		34		
<b>ENGINE FUEL CONSUMPTION (Natural Gas) (Propane)</b>		<b>Natural Gas</b>	<b>Propane</b>	
		(ft <sup>3</sup> /hr.)	(gal/hr.)	cu ft/hr
Exercise cycle		60	0.65	24
25% of rated load		124	1.35	49
50% of rated load		188	2.05	75
75% of rated load		250	2.73	99
100% of rated load		315	3.44	125
<b>ENGINE COOLING</b>				
Air flow (inlet air including alternator and combustion air) ft <sup>3</sup> /min.		1,528		
System coolant capacity US gal.		2.0		
Heat rejection to coolant BTU/hr.		107,000		
Max. operating air temp. on radiator °C (°F)		60 (150)		
Max. ambient temperature °C (°F)		50 (140)		
<b>COMBUSTION AIR REQUIREMENTS</b>				
Flow at rated power 60 Hz cfm		91		
<b>SOUND EMISSIONS IN DBA</b>				
Exercising at 7 meters		62		
Full load at 7 meters		75		
<b>EXHAUST</b>				
Exhaust flow at rated output 60 Hz cfm		177		
Exhaust temp. at muffler outlet °F		910		
<b>ENGINE PARAMETERS</b>				
Rated synchronous RPM 60 Hz		3600		
HP at rated KW 60 Hz		34.8		
<b>POWER ADJUSTMENT FOR AMBIENT CONDITIONS</b>				
Temperature Deration				
3% for every 10 °C above - °C		40		
1.65% for every 10 °F above - °F		104		
Altitude Deration				
1% for every 100 m above - m		914		
3% for every 1000 ft. above - ft.		3000		

RATING: All three phases units are rated at 0.8 power factor. All single phase units are rated at 1.0 power factor. STANDBY RATING: Standby ratings apply to installations served by a reliable utility source. The standby rating is applicable to varying loads for the duration of a power outage. There is no overload capability for this rating. Ratings are in accordance with ISO-3046-1. Design and specifications are subject to change without notice.

KW rating is based on LPG Fuel and may derate with natural gas.

## C1 Enclosure 20-25 KW QT

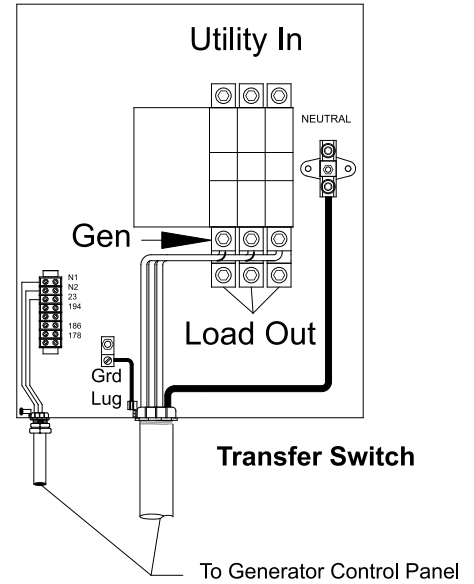
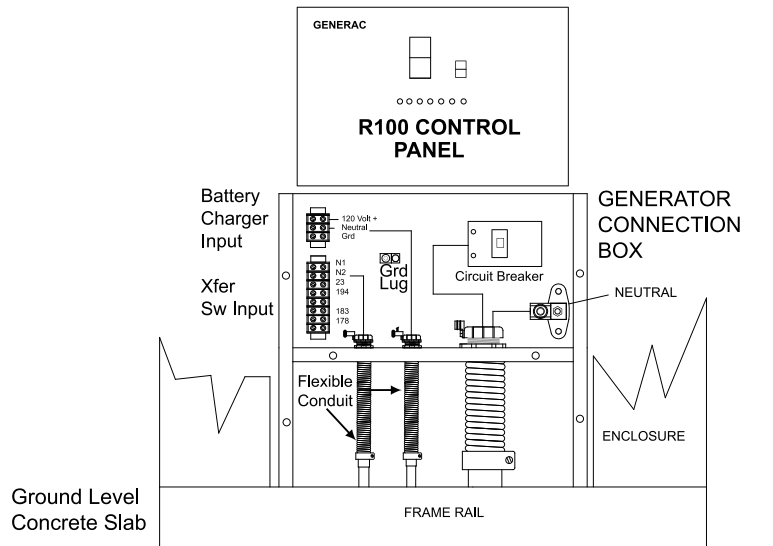

### CIRCUIT BREAKER SIZE

KW	VOLTS	AMPS	LUG SIZE
25	240 1 $\phi$	125	#6 to 300 mcm
25	208 3 $\phi$	100	#6 to 300 mcm

# INSTALLATION LAYOUT

